



A Note on Measuring Coaxial Coupler Directivity

A question frequently asked concerning the -hp- coaxial directional couplers* is how the directivity is measured in those couplers that operate in the region below about 1,000 megacycles. The significance of this question is that at these relatively long wavelength frequencies it is mechanically impractical to construct the high performance coaxial sliding loads that are usually used for directivity measurements.

SEE ALSO:
High-resolution
DB scales for -hp-
VTVM's, p. 3

Schematically, the -hp- coaxial couplers have a circuit arrangement like that shown in Fig. 2. It can be seen that each coupler is in effect two couplers placed back-to-back, an arrangement that makes them convenient and economical for reflectometer work. The coupling from the main arm to each auxiliary arm is nominally -20 db. Theoretically, power flowing to the right in the main arm should be coupled only to the *Forward* terminal, and power flowing

to the left should be coupled only to the *Reverse* terminal. Some small amount of unwanted power usually reaches the wrong terminal, however, and the ratio of this unwanted power to the coupled power defines the directivity of the coupler. In the two -hp- couplers that jointly cover the region between 216 and 945 megacycles, the directivity is specified as being at least 30 db. Since the coupling value is 20 db, the power reaching the wrong terminal from a wave in the main arm is at least 50 db below the main arm power level. This low value is a distinguishing characteristic of the couplers and enables them to be used with suitable detecting equipment to measure reflection coefficients down to the order of 0.05-0.1 — quite low values for typical coaxial systems.

*J. K. Hunton, H. C. Poulter, and C. S. Reis, "High-Directivity Coaxial Directional Couplers and Reflectometers," Hewlett-Packard Journal, Vol. 7, No. 2, October, 1955.

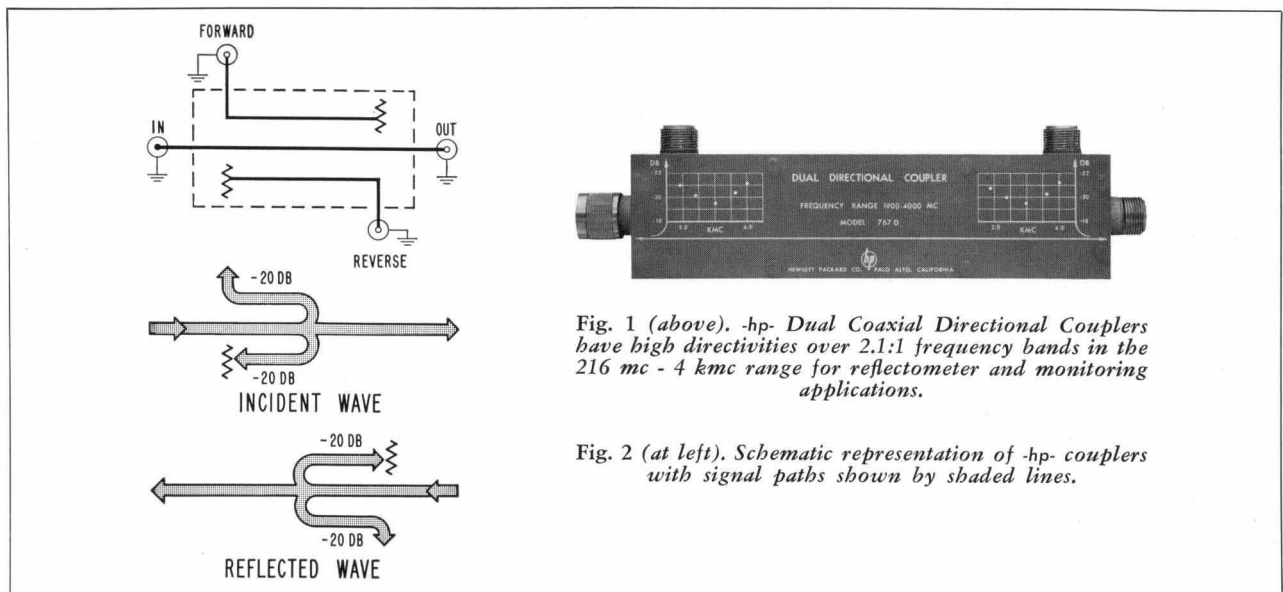
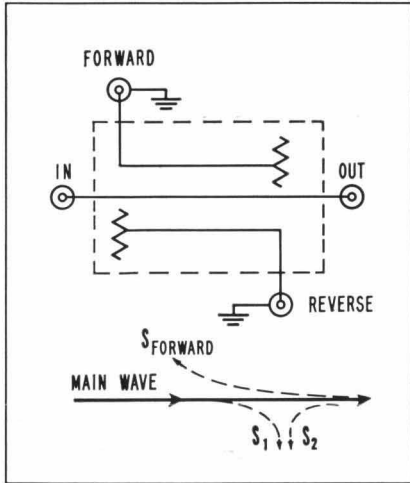

Fig. 1 (above). -hp- Dual Coaxial Directional Couplers have high directivities over 2.1:1 frequency bands in the 216 mc - 4 kmc range for reflectometer and monitoring applications.

Fig. 2 (at left). Schematic representation of -hp- couplers with signal paths shown by shaded lines.



MEASUREMENT SETUP

The signals that account for the lack of perfect directivity in the couplers are indicated in Fig. 3 for a wave flowing to the right in the main arm. First, a small signal S_1 reaches the *Reverse* terminal because of imperfection in the coupling mechanism itself. Second, the output connector on the main arm will not be perfectly matched to the main arm and will therefore reflect a small signal, part of which (S_2) will reach the *Reverse* terminal.

The problem in measuring the directivity of the couplers is to measure the magnitude of the vector sum of these two signals at the *Reverse* terminal exclusive of any signal reflected to the same terminal from a termination placed on the output end of the couplers. In the *-hp-* laboratory this measurement is made

COUPLING CURVE SHOWN ON COUPLER

THE *-hp-* coaxial directional couplers are currently rated as having a mean coupling value that is within ± 0.5 db of 20 db and a frequency response characteristic that is constant within ± 1 db over the complete rated 2.1:1 frequency range. This high order of performance is now further supplemented by an individual coupling calibration curve which is permanently marked on the couplers at the factory. The calibration is in the form of a frequency vs. coupling value grid which is marked in red at each frequency at which the coupling is measured. When highest accuracy is sought, the user can thus easily apply a correction to his measurement. Each coupler is provided with two such calibrations, one for each half of the coupler.

Fig. 3 (at left). Small spurious signals S_1 and S_2 at Reverse terminal constitute directivity signal.

Fig. 4 (at right). Setup used to measure directivity of couplers.

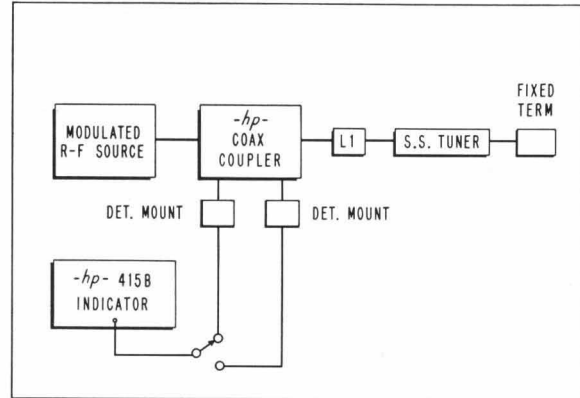

with the arrangement indicated in Fig. 4. The coupler is fed with a source of modulated r-f power and is connected to a slide-screw tuner through a short length of precision rigid line L_1 whose length is accurately known and which has special connectors, as described later. The tuner is terminated in a fixed load of good performance, although this factor is not critical. The slide-screw tuner can be a slotted line section in which the sampling probe is replaced with a larger metallic post to give a suitably large reflection. The signals appearing at the terminals are detected with crystal detectors and their ratio is measured with the *-hp-* 415B Indicator.

Using this arrangement, the tuner is adjusted both in probe penetration and position until a null is obtained at the *Reverse* terminal. The condition that then exists at the *Reverse* terminal is indicated in Fig. 5. S_1 and S_2 add in some unknown phase to give a resultant magnitude S_{dir} . The net reflection from the tuner and its termination S_3 is equal in magnitude to S_{dir} but is in phase opposition to give a null at the *Reverse* terminal. A signal has thus been established which is equal in magnitude to the directivity signal but which is exactly out of phase with that signal.

The next step in the procedure is to replace the line section L_1 with a line L_2 which is one-quarter wavelength longer than L_1 . This is done without disturbing the adjustment of the probe. The total path length

for the signal that produces S_3 is thus increased by one-half wavelength, so that S_3 will now be directly in phase with S_{dir} . The total signal voltage at the *Reverse* terminal will then be exactly twice as large as S_{dir} itself. The directivity is then found by halving the measured ratio of the total signal voltage at the *Reverse* terminal to the signal voltage at the *Forward* terminal. In db terms the directivity as measured by this procedure should be increased by 6 db, i.e.,

$$\text{Directivity} = 20 \log \frac{S_{\text{forward}}}{S_{\text{dir}} + S_3} + 6 \text{ db.}$$

The directivity for the *Forward* terminal is found by reversing the connections to the coupler and repeating the above process for the *Forward* terminal. (Cont'd. on p. 4)

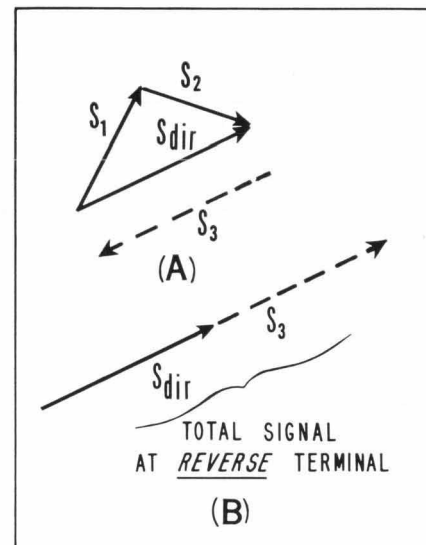

Fig. 5. (a) Reflection from slide-screw tuner is adjusted until its component S_3 at Reverse terminal is equal and opposite to S_{dir} . (b) When line L_2 replaces L_1 , S_3 is equal to and in phase with S_{dir} .

HIGH DB-RESOLUTION METER SCALES FOR -hp- VTVM'S

Some applications, particularly some in the communications industry, require reading voltage levels directly in decibels and to high resolutions. To facilitate this work, the -hp- Models 400D and 400H VTVM's are now available with special meters on which the DB scale has been emphasized.

Figs. 1 and 2 show scaled reproductions of the new optional meters. The DB scale has been located at the top of the face, a location that gives the scale 25% more length than on the regular meter. This additional length has made it possible to graduate the scale in minor divisions of 0.2 db.

DB RANGE

As is standard on -hp- meters, the DB scale is calibrated with 0 db equal to 1 milliwatt in 600 ohms (0.775 volt). In addition, the ranges of the voltmeters are separated by exactly 10 db, so that direct readings in db can be made over the complete voltage range of the instruments. This range extends from -72 db (0.2 millivolt) (-75 db in the case of the Model 400D) to +52 db (300 volts). As can be seen in the illustrations, good readability is also retained for the 1 and 3 voltage ranges for cases where direct voltage readings are desired.

Both the Model 400D and the Model 400H operate with high accuracy over the exceedingly wide frequency range of 10 cps to 4 megacycles. The Model 400H has a rated accuracy of within $\pm 1\%$ over the audio and lower r-f regions of this range and is provided with a 5-inch, $\pm \frac{1}{2}\%$ movement with mirror scale and knife-edge pointer. The Model 400D has a rated accuracy of within $\pm 2\%$ over a similar range and is provided with a 4-inch movement with knife-edge pointer.

LOW G_m SENSITIVITY

The voltmeters are further designed so that they have a high order of insensitivity to tube replacement. An entire set of replacement tubes can all have G_m 's 20% above or below rated value for their types before a discernible change occurs in mid-band calibration.

In other respects the Models 400D and 400H are essentially identical. They both have extremely high input impedances, can both be used as high-gain amplifiers, and are both provided with tilt-up bails to place the instruments at a convenient viewing angle for bench use.

(Cont'd. on p. 4)

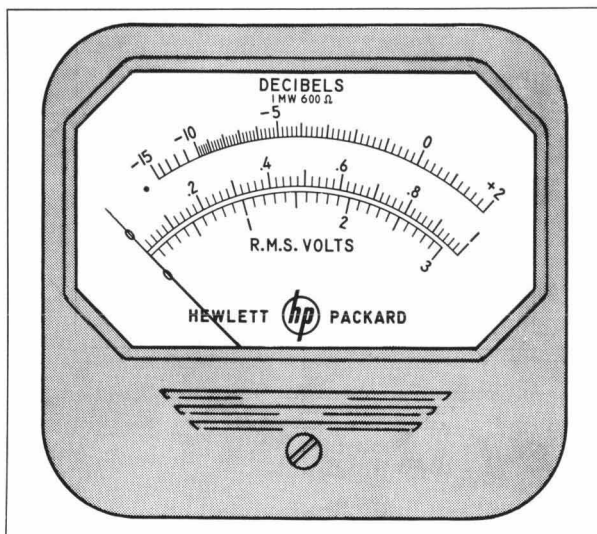

Fig. 1. Two-thirds scale reproduction of Model 400D-DB meter face.

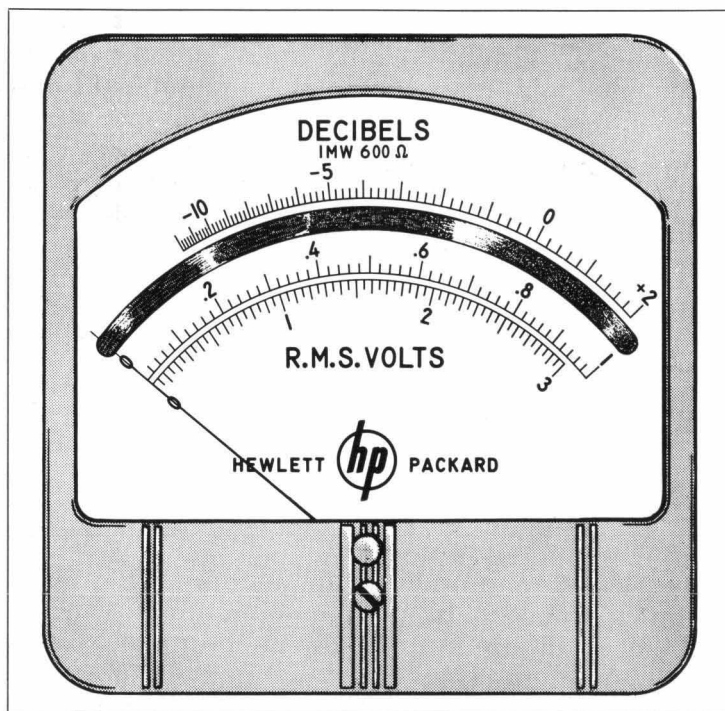

Fig. 2. Two-thirds scale reproduction of Model 400H-DB meter face.

SPECIFICATIONS

MODELS 400D-DB AND 400H-DB VACUUM-TUBE VOLTMETERS

Voltage Range: 0.1 millivolt to 300 volts, 12 ranges, selected with front panel switch. Full scale readings of 0.001, 0.003, 0.010, 0.030, 1.0, 3.0, 10.0, 30, 100, 300 volts.

Frequency Range: 10 cps to 4 megacycles.

Model 400D Accuracy: With line voltages of nominal voltage $\pm 10\%$ (103 volts to 127 volts), overall accuracy is: within $\pm 2\%$ of full scale value, 20 cps to 1 mc; within $\pm 3\%$ of full scale value, 20 cps to 2 mc; within $\pm 5\%$ of full scale value, 10 cps to 4 mc.

Model 400H Accuracy: With line voltages of nominal voltage $\pm 10\%$ (103 volts to 127 volts), overall accuracy is: within $\pm 1\%$ of full scale value, 50 cps to 500 kc; within

$\pm 2\%$ of full scale value, 20 cps to 1 mc; within $\pm 5\%$ of full scale value, 10 cps to 4 mc.

Long Term Stability: Reduction in G_m of amplifier tubes to 75% of nominal value results in error of less than 0.5%, 20 cps to 1 mc.

Calibration: Reads rms value of sine wave. Voltage indication proportional to average value of applied wave. Linear voltage scales, 0 to 3 and 0 to 1.0; db scale, -12 db to +2 db, based on 0 dbm = 1 mw in 600 ohms, 10 db intervals between ranges.

Input Impedance: 10 megohms shunted by 15 μf on ranges 1.0 volt to 300 volts; 25 μf on ranges 0.001 volt to 0.3 volt.

Amplifier: Output terminals are provided so voltmeter can be used to amplify small signals or to monitor waveforms under test with an oscilloscope. Output approx-

imately 0.15 volts rms on all ranges with full scale meter deflection. Amplifier frequency response same as that of voltmeter. Internal impedance approximately 50 ohms over entire frequency range.

Power Supply: 115/230 volts $\pm 10\%$, 50/1,000 cps, approx. 100 watts.

Size: Cabinet Mount: 11 $\frac{1}{2}$ " high, 7 $\frac{1}{2}$ " wide, 11 $\frac{3}{4}$ " deep. Rack Mount: 19" high, 7" wide, 12" deep.

Weight: Cabinet Mount: 18 lbs.; shipping weight approximately 25 lbs. Rack Mount: 22 lbs.; shipping weight approximately 35 lbs.

Price: Model 400D-DB Vacuum Tube Voltmeter, Cabinet Mount, \$237.50. Model 400DR-DB, \$242.50; Model 400H-DB Vacuum Tube Voltmeter, Cabinet Mount, \$337.50. Model 400HR-DB, \$342.50.

All prices f.o.b. Palo Alto, California. Data subject to change without notice.

COUPLERS

(Cont'd. from p. 2)

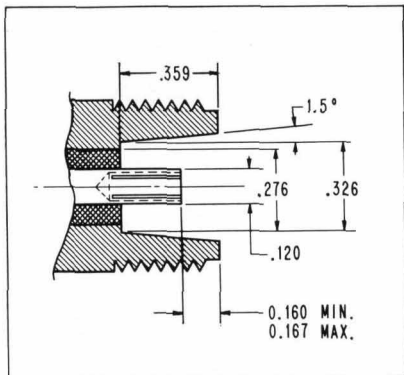

MEASUREMENTS AT OTHER FREQUENCIES

Since the two lines used for connecting the coupler to the tuner in the above procedure can be a quarter wavelength different in length at only one frequency, it would at first appear necessary to use a different pair of lines for each frequency at which a measurement is to be made. In practice, however, this is not necessary, because standard corrections can be applied for the other frequencies at which the pair is used. The correction can easily be calculated at each frequency by determining the total difference in path length that occurs for S_3 when one line is used in place of another. This leads to a standard correction curve like that shown in Fig. 6.

CONNECTOR CONSIDERATIONS

From an applications standpoint the performance of the output connector on the coupler must be taken into account by the designer and any adverse effect of this connector must be included in the coupler's specified performance. The type N

VTVM's

(Cont'd. from p. 3)

When provided with the special DB meters, the Model 400D is known as the 400D-DB and the 400H as the 400H-DB.

More details about the basic instruments are given in the following issues:

Model 400D: Hewlett-Packard Journal, Vol. 5, No. 9, May, 1954. Model 400H: Hewlett-Packard Journal, Vol. 7, No. 4, December, 1955.

Fig. 7 (at left). Mechanical detail of output jack provided on -hp- coaxial couplers.

Fig. 8 (at right). Mechanical detail of external rigid line that can be used to make "connectorless" connection to output connector on coupler.

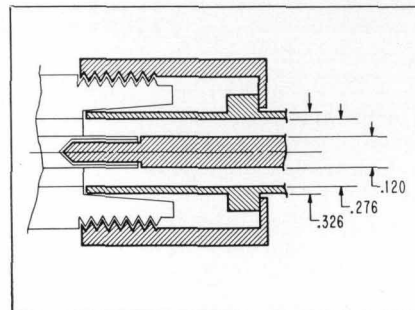

output connector provided on the coupler has therefore been designed to offer improved performance over a standard type N connector. To achieve this, the connector is altered in three ways. First, the slots in the center conductor of the type N output jack are made considerably shorter than those of a standard type N jack. Second, the outer diameter of the center conductor is made such that no step in diameter occurs in the center conductor at the transition when the jack is connected to

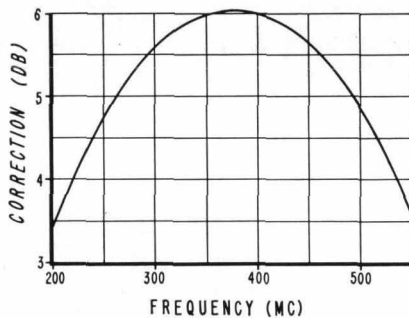

Fig. 6. Typical correction curve used to enable one set of line sections to suffice over full 2.1:1 range of coupler in directivity measurements.

an external plug. Third, the inner diameter of the outer conductor in the plug has been made equal to the outer diameter of the outer conductor of a standard type N plug. This measure keeps the outer conductor of the plug from being compressed when it is connected to the jack on the coupler. Consequently, it does away with the step that usually occurs in the inner surface of the outer conductor when a type N plug and jack are connected.

Not only do the foregoing measures improve the performance of the jack provided on the coupler without impairing its ability to be con-

nected to a standard type N plug, but they also offer the user the possibility of connecting to the coupler with a connectorless rigid line of high performance. To obtain optimum results the rigid line should be arranged so that its center conductor will make a gapless connection to the center conductor on the coupler connector. This means that the center conductor should be specially machined so that its shoulder extends the proper distance into the jack. In the -hp- coaxial coupler jacks this distance is held between 0.160" and 0.167" from the outer edge of the jack. The outer conductor of the line should have an O.D. of 0.326" and an I.D. of 0.276".

These measures for the connecting line are suggested only for the case where the performance of some device is to be investigated exclusive of its connector. If the device is such that a type N plug is normally attached to it, it will normally be tested using such a plug and its rating must include the effect of the plug. The improved connector on the coupler does, however, offer the user considerable flexibility.

These considerations are also followed in the construction of lines L_1 and L_2 used in the testing procedure so that essentially no reflection occurs between the output connector on the coupler and these lines. Further, the two lines are carefully constructed so that any reflection that occurs between one line and the tuner will be the same as with the other line and the tuner. This is practical at frequencies below 1,000 mc.

—Howard C. Poulter